

MTH & CF Multi-Truss Hanger

The MTH range is a face fix hanger for use in heavy duty applications such as multiple truss units, main trimmer joists, purlin to beam connections or similar situations where unusually heavy loads occur. Manufactured from 1.5mm thick galvanised steel. Bolt hole to suit M12 fixing, nail holes 5mm diameter. Produced from galvanised steel to BS EN 10346 + G275 as standard. Stainless steel hangers are available to order. Bearing surface on all multi-truss hangers is 75mm.

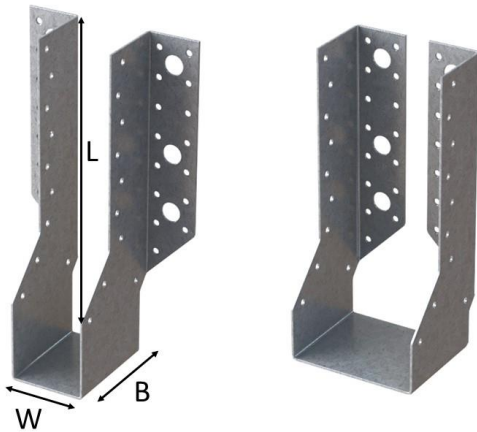

* Available at MTH/CF/500 with face plates folded inwards for concealed flange

Product

MTH

Features:

- Heavy Duty
- M12 Bolt holes (Fixing specification by building designer)

Fixings:

- Type A, 30 x 3.75mm Sherardised Square Twist Nails
- Type B, 35 x 3.75mm.

Approvals:

- CE Marked
- UKCA Marked

Packaging:

- Box Quantities of 25

Load Directions

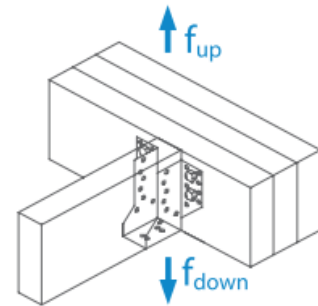

Product code	Dimensions (mm)			Holes no. 5.0 Ø (mm)			Product Details											
							C16 Timber						C24 Timber					
	W	L	B	Face Flange	Side Flange	Type A Nails		Type B Nails		Type A Nails		Type B Nails		Type A Nails		Type B Nails		
						F _{up}	F _{down}	F _{up}	F _{down}	F _{up}	F _{down}	F _{up}	F _{down}	F _{up}	F _{down}	F _{up}	F _{down}	
MTH/500/38	38	231	75	30	6x13.0Ø	20	11.09	20.48	11.65	21.73	12.52	23.12	13.15	23.99	13.24	24.26	13.91	25.01
MTH/500/44	44	228					12.29		13.49	23.78	13.87	23.12	15.23	26.29	14.66	24.44	16.10	27.45
MTH/500/47	47	226					12.29		14.41	24.07	13.87	23.12	16.27	27.17	14.66	24.44	17.20	28.67
MTH/500/50	50	225					12.29		14.44	24.07	13.87	23.12	16.30	27.17	14.66	24.44	17.24	28.71
MTH/500/63	63	218					12.29		14.44	24.07	13.87	23.12	16.30	27.17	14.66	24.44	17.24	28.71
MTH/500/75	75	212					12.29		14.44	24.07	13.87	23.12	16.30	27.17	14.66	24.44	17.24	28.71
MTH/500/88	88	206					12.29		14.44	24.07	13.87	23.12	16.30	27.17	14.66	24.44	17.24	28.71
MTH/500/91	91	204					12.29		14.44	24.07	13.87	23.12	16.30	27.17	14.66	24.44	17.24	28.71
MTH/500/100*	100	200					12.29		14.44	24.07	13.87	23.12	16.30	27.17	14.66	24.44	17.24	28.71
MTH/500/125*	125	187					12.29		14.44	24.07	13.87	23.12	16.30	27.17	14.66	24.44	17.24	28.71
MTH/500/150*	150	175					10.92		12.84	24.07	12.33	23.12	14.49	27.17	13.03	24.44	15.32	28.71

Note: Refer to fixing data sheet for fixing information.